

BR-2/3A

■ Dimensions(mm)

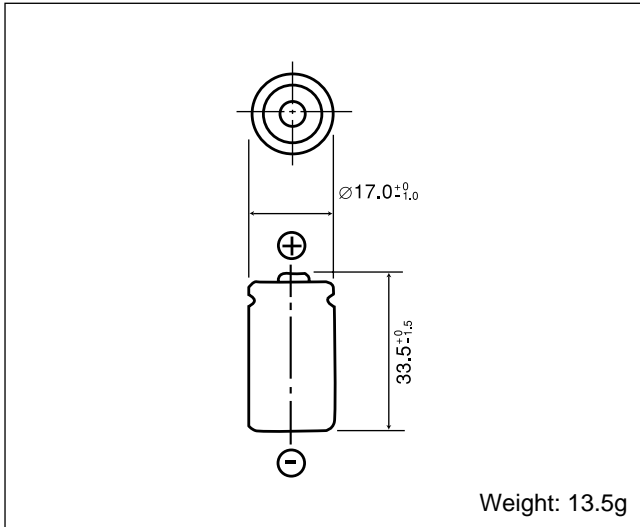

■ Specification

Nominal voltage(V)	3
Nominal capacity(mAh)	1,200
Continuous standard load(mA)	2.5
Operating temperature(°C)	-40 ~ +85

■ Temperature Characteristics

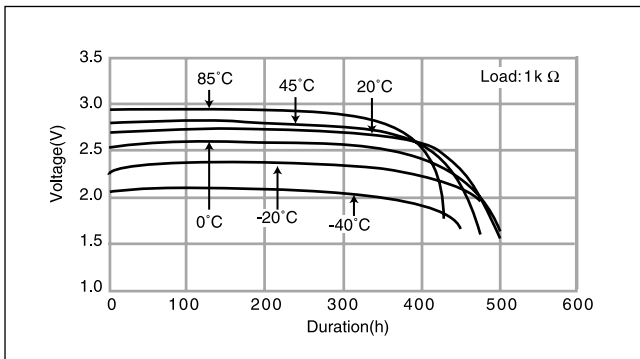

■ Operating voltage vs. Discharge current (voltage at 50% discharge depth)

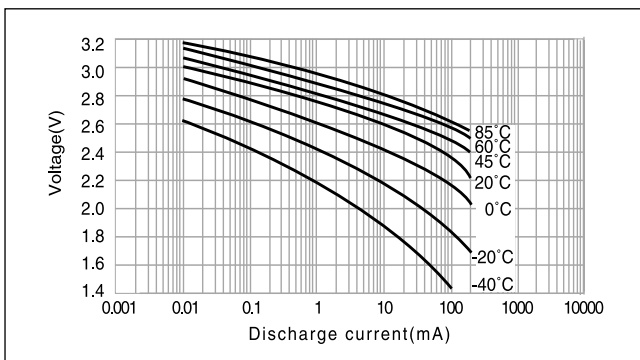

BR-2/3AH

■ Dimensions(mm)

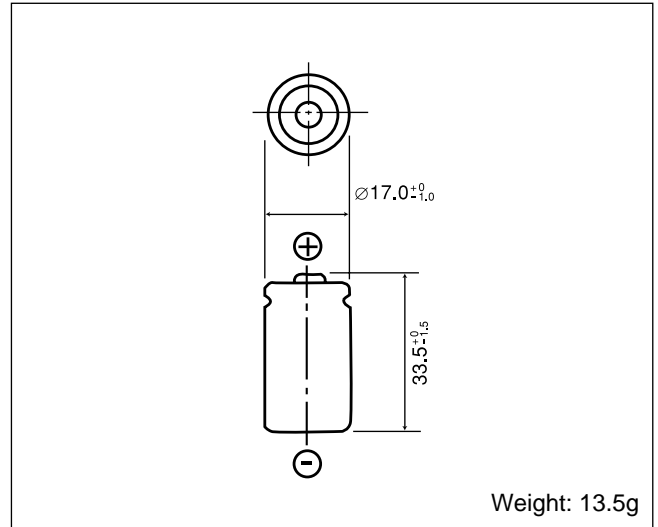

■ Specification

Nominal voltage(V)	3
Nominal capacity(mAh)	1,350
Continuous standard load(mA)	2.5
Operating temperature(°C)	-40 ~ +85

■ Temperature Characteristics

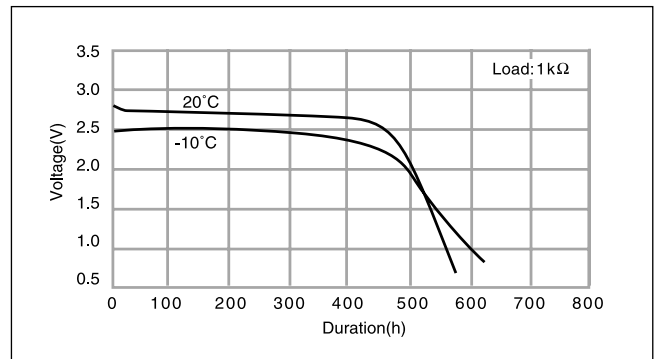

■ Operating voltage vs. Discharge current (voltage at 50% discharge depth)

