

LC-X06200

For standby power supplies.
Expected trickle design life: 10 – 12 years at 20 °C according to Eurobat.

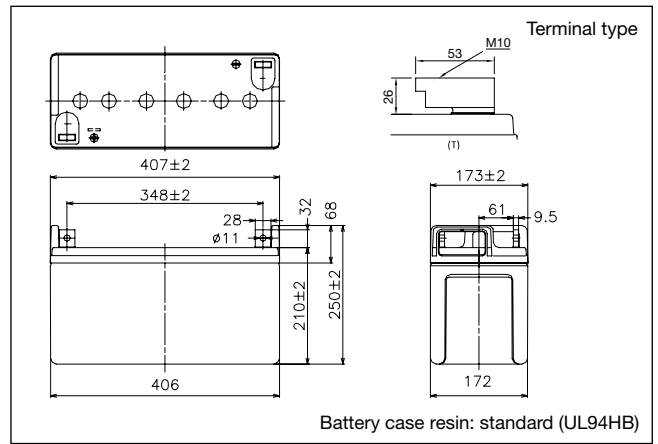

Dimensions (mm)



Specifications

Nominal voltage	6 V	
Nominal capacity (20 hour rate)	200 Ah	
Dimensions	Length	407 mm
	Width	173 mm
	Height	210 mm
	Total Height	250 mm
Approx. mass	41 kg	
Terminal	M10 Bolt and Nut type	

Duration of discharge vs Discharge current

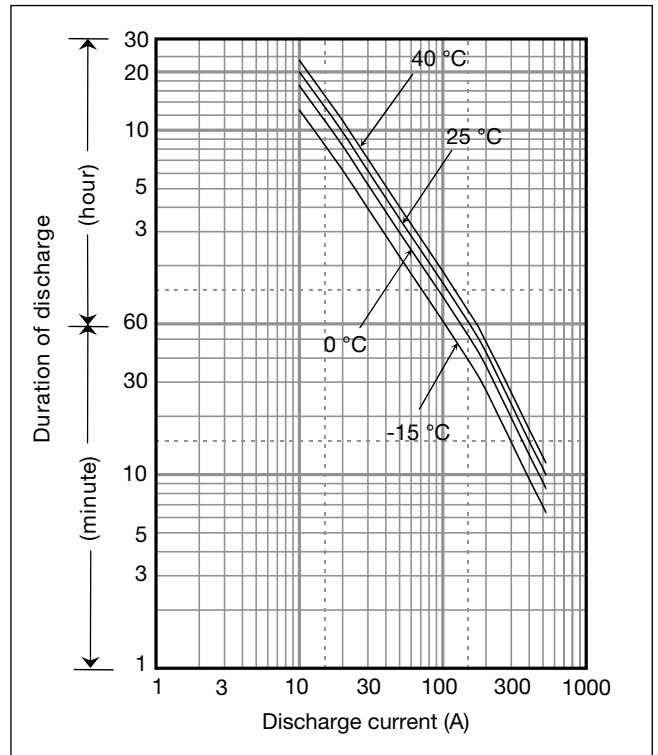

Characteristics

Capacity (25 °C)	20 hour rate	200 Ah
	10 hour rate	194 Ah
	5 hour rate	184 Ah
	1 hour rate	120 Ah
Internal resistance	Fully charged battery (25 °C)	2 mΩ
Temperature dependency of capacity (20 hour rate)	40 °C	102 %
	25 °C	100 %
	0 °C	85 %
	-15 °C	65 %
Self discharge (25 °C)	After 3 months	91 %
	After 6 months	82 %
	After 12 months	64 %

Watt Table

(Wattage/Battery)

Cut-off V	10min	15min	20min	30min	45min	1h	1.5h	2h	3h	4h	5h	6h	10h	20h	24h
4.8V	2306	1834	1592	1206	892	733	582	430	281	226	170	154	88.3	47.0	38.5
4.95V	2254	1790	1554	1177	869	714	567	419	276	221	165	149	85.3	47.0	38.5
5.1V	2204	1726	1498	1139	877	694	551	413	272	216	160	145	84.3	46.5	38.0
5.25V	2134	1705	1487	1130	852	675	536	405	267	213	160	145	83.3	46.5	38.0
5.4V	1947	1624	1479	1094	840	666	528	395	262	208	155	150	82.3	45.5	37.2

Ampere Table

(Ampere/Battery)

Cut-off V	10min	15min	20min	30min	45min	1h	1.5h	2h	3h	4h	5h	6h	10h	20h	24h
4.8V	530	402	348	260	184	153	104	82.6	55.4	42.8	37.2	31.2	19.8	10.0	8.4
4.95V	524	400	346	258	179	152	102	82.0	54.4	42.4	36.6	31.2	19.8	10.0	8.4
5.1V	522	398	342	254	178	151	101	81.0	54.0	42.0	36.0	31.0	19.6	10.0	8.4
5.25V	476	376	326	250	176	150	100	80.0	54.0	42.0	36.0	31.0	19.6	10.0	8.4
5.4V	452	364	318	246	152	130	90	76.0	51.6	41.0	35.6	30.0	19.4	9.8	8.4

Charging Method

Trickle use Control voltage: 6.8 - 6.9 V; Initial current 30 A or smaller

Cut off voltage

Discharge current	10 A - 40 A	40 A - 100 A	100 A - 200 A	200 A - 400 A	400 A - 600 A
Cut off voltage (V)	5.25	5.1	4.95	4.65	4.35

Influence of Temperature on Trickle life

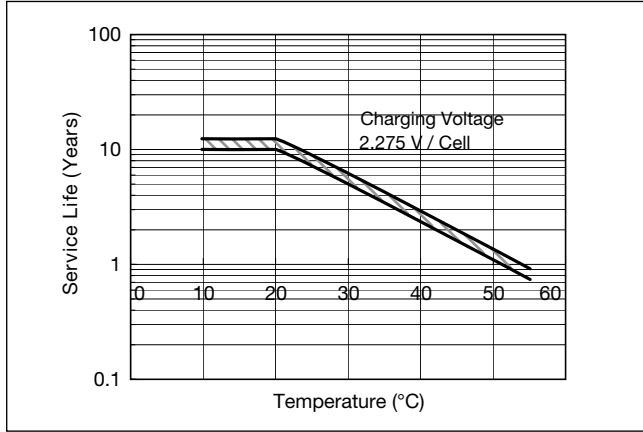

Residual capacity vs storage period

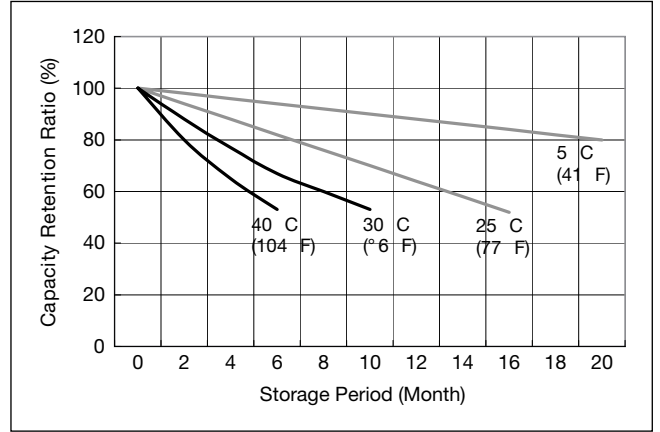

Constant-voltage and constant-current charge characteristics for Trickle use

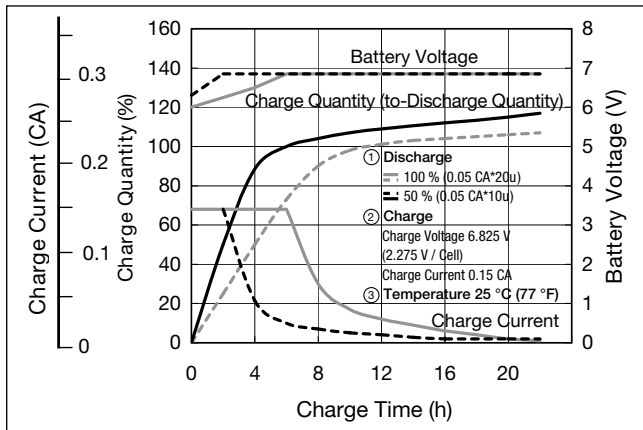

Discharge capacity by temperature and by discharge current

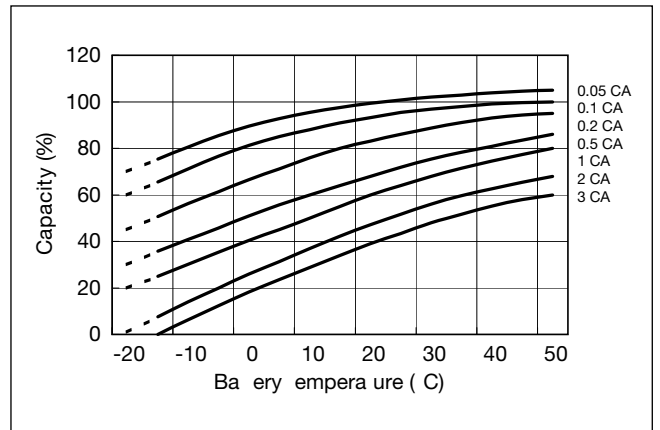

Discharge characteristics

